

Dialog item	Value	Description (continued)
V 7.X	Lev0... Lev2	Programming lock:
		Version display with current input level: 0: only display of operating parameters, no changes possible 1: only switching points can be set and "max" and "min" memories 2: release user level (all operating parameters for customer)
LITH	20... 100	Change display brightness 20... 100% (only for units with dot-matrix display)
AOZS (only V 7.X)	0... 9999	Scale the analog output - start value (e. g. 0 bar = 4 mA)
AOFS	0... 9999	Scale the analog output - end value (e. g. 400 bar = 20 mA) (output signal start value always corresponds to the display initial value, e. g. 0 bar = 4 mA), max. turn-down 4: 1, i. e. at values below 25 % of the measuring range the analog output is switched off
Code	000... 999	Enter the code level: Changes: Lev1: 471 (up + down 5 seconds) Lev1 - Lev0 Lev2: 740 (up + down + M 5 seconds) Lev2 - Lev0 Lev0: 999
OPT (only V 7.X)	----	Display of the unit options stored by the manufacturer Barksdale.

Operating Instructions Dual Pressure Switch UDS 7 Dual Temperature Switch UTS 7



1	Intended Applications	2
2	Safety Instructions	2
3	Standards.....	3
4	Warranty/Guaranty	3
5	Installation/Commissioning	4
6	Maintenance/Cleaning	5
7	Technical Data	6
8	Operation	8
9	Programming	9
10	User Level Dialog	10

Barksdale GmbH
Dorn-Assenheimer Straße 27
D-61203 Reichelsheim

Phone: +49 (6035) 949-0
Fax: +49 (6035) 949-111 and 949-113
email: info@barksdale.de
Internet: www.barksdale.de

Art. no. 923-1724
Index E, 19.08.2009
Software version: from V 1.X



Specifications are subject to changes
without notice!

1 Intended Applications

The dual pressure switch monitors system pressures and has up to two switching outputs and one analog output.

The dual temperature switch monitors the temperature of the medium into which the probe is immersed and has up to two switching outputs and one analog output.

 DANGER
<p>The switch may only be used in the specified fields of application.</p> <p>The temperature must be within the specified ranges, the pressure values and the electrical rating must not exceed the values specified.</p> <p>Observe also the applicable national safety instructions for assembly, commissioning and operation of the switch.</p> <p>The switch is not designed to be used as the only safety relevant element in pressurized systems according to DGR 97/23/EC.</p>

2 Safety Instructions

The safety instructions are intended to protect the user from dangerous situations and/or material damage.

In the operating instructions the seriousness of the potential risk is designated by the following signal words:

 DANGER
<p>Refers to imminent danger to men.</p> <p>Nonobservance may result in fatal injuries.</p>

 WARNING
<p>Refers to a recognizable danger.</p> <p>Nonobservance may result in fatal injuries, and destroy the equipment or plant parts.</p>

 CAUTION
<p>Refers to a danger.</p> <p>Nonobservance may result in light injuries and material damage to the sensor and/or to the plant.</p>

 IMPORTANT
<p>Refers to important information essential to the user.</p>

	<p>Disposal</p> <p>The sensor must be disposed of correctly in accordance with the local regulations for electric/electronic equipment.</p> <p>The switch must not be disposed of with the household garbage!</p>
-------------------------------------------------------------------------------------	--------------------------------------------------------------------------------------------------------------------------------------------------------------------------------------------------------------------------

3 Standards

The standards applied during development, manufacture and configuration are listed in the CE conformity and manufacturer's declaration.

4 Warranty/Guaranty

Warranty

Our scope of delivery and services is governed by the legal warranties and warranty periods.

Terms of guaranty

We guaranty for function and material of the dual pressure and temperature switch under normal operating and maintenance conditions in accordance with the statutory provisions.

Loss of guaranty

The agreed guaranty period will expire in case of:

- incorrect use,
- incorrect installation or
- incorrect handling or operation contrary to the provisions of these operating instructions.

No liability is assumed for any damage resulting therefrom, or any consequential damage.

5 Installation/Commissioning

 **DANGER**

Only install or uninstall the switch when deenergized (electrically and hydraulically/pneumatically).
Pressure connection and electrical connection must be carried out by trained or instructed personnel according to state-of-the-art standards.
The switch must only be installed in systems where the maximum pressure P_{max} or the maximum temperature T_{max} is not exceeded (see type label).

 **WARNING**

Be aware of the fact that in case of operation with higher temperatures the casing surface may become very hot!

 **CAUTION**

Mount the pressure switch from bottom to the fitting with a wrench SW 36 (1/4") resp. 19 with 45 Nm torque.
Do not operate the switch if the switch itself or the connection cable is damaged. Impact and heavy vibrations during transportation should be avoided.
Even if the switch casing remains undamaged, inside parts may be damaged and cause malfunctions.

Electrical connection depends on the type of pressure switch (see type label) according to the chart below.

Wrong assignment of the connections may cause malfunctions or incorrect switch outputs.

Connection Chart

Plug M 12x1 4-pin / 5-pin	Model with 2 switching outputs	Model with 2 switching outputs and 1 analog output
Pin 1	+Ub: 18... 32 V DC	+Ub: 18... 32 V DC
Pin 2	SP2 0.5 A max.	analog: 4... 20 mA / 0... 10 V DC
Pin 3	0 V	0 V
Pin 4	SP1 0.5 A max.	SP1 0.5 A max.
Pin 5		SP2 0.5 A max.

6 Maintenance/Cleaning

Maintenance

The pressure/temperature switch requires no maintenance.

Cleaning

 **CAUTION**

The membrane keys may be damaged by the use of unsuitable cleaning agents. Do not use any cleaning agents containing solvents or abrasive additives.

7 Technical Data

	UDS 7	UTS 7
Measuring element	Piezoresistive pressure sensor with internal stainless steel diaphragm	Pt100 (class B) according to DIN IEC 751
Measuring ranges	0... 1 bar to 0... 10 bar 0... 15 psi to 0... 150 psi absolute pressure 0... 10 bar to 0... 600 bar 0... 150 psi to 0... 9000 psi relative pressure	0 ... +100 °C to -30 ... +150 °C +32 ... +212 °F to -22 ... +302 °F
Display	4-digit dot-matrix display, green, digit height 5 mm	
Switching outputs	2 x transistor switching output, pnp NO/NC function (programmable), adjustable switching time delay 0... 9.9 s	
Operating temperature range	-10 ... +70°C / +14 ... +158 °F	
Media temperature range	-25 ... +100°C / -13 ... +212 °F	-30 ... +150°C / -22 ... +302 °F
Process connection (fitting "A" without adapter)	G ¼, G ½ front flush 1/4" – 18 NPT 7/16 – 20 SAE	G ¼, 1/4" – 18 NPT
Protection system/class	Nema 4X, IP65/III	
Electrical connection	Plug 5-pin, M 12x1	
Auxiliary power	18... 32 V DC	
For further technical data and options please refer to the data sheets		

Operating and display elements/Dimensions Dimensions in mm

Dual pressure switch UDS7

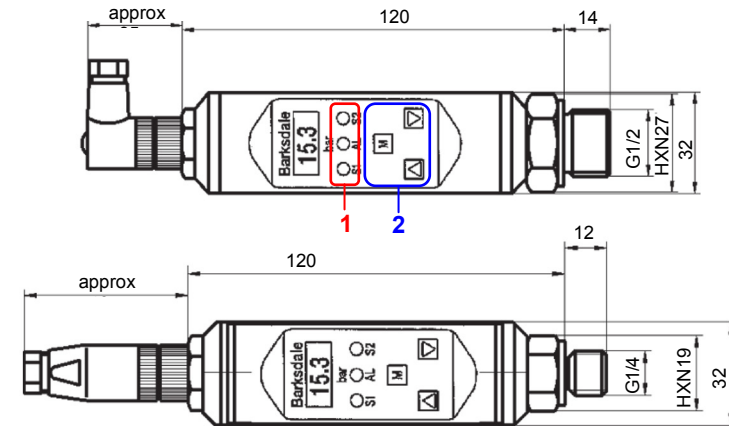

LEDs (1)	
AL	(yellow) – alarm
S1	(green) – switching point 1
S2	(green) – switching point 2

Membrane keys (2)	
M	Dialog item "change to value/to function", acknowledge inputs
▲	Change dialog items/functions, change numerical values
▼	

Dual temperature switch UTS7

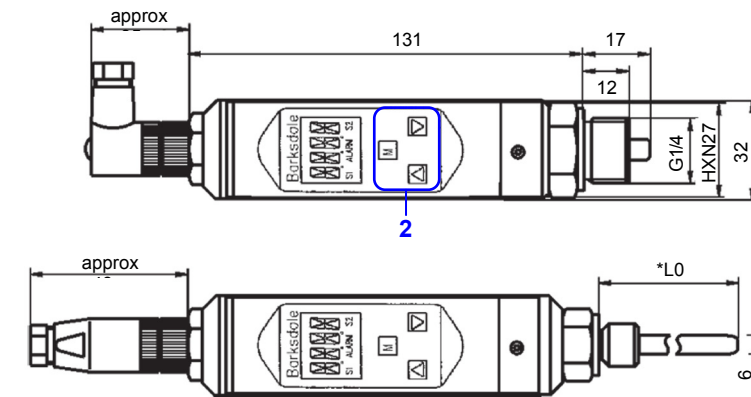

8 Operation

The switch may be installed and operated only by authorized persons. Do not use any hard objects for making entries.

In case of first commissioning a self-test is performed. The device is menu-operated via three membrane keys, which must **not** be touched with any hard objects.

If an error is detected during the self-test or normal operation, this error is signaled by a (yellow) flashing alarm LED (AL). The error can be read out in the menu ERRC.

The green LEDs S1 and S2 signal the activity of the two switching points.

9 Programming

1		After switching on with M change to the first dialog item.
2	Change dialog item	Select the desired dialog item with ▼ or ▲. (see chapter 10 „User Level Dialog“)
3	Activate dialog item Value input/function selection	Activate the desired dialog item with M to change the corresponding value or the desired function.
4	Change value	Select the individual digits with M . Change the numerical value with ▼ or ▲ and acknowledge with M . If the entered value is within the permissible range, the system changes to the dialog item after input of the last digit, otherwise the 1st digit will flash again.
5	Change function	Change the function with ▼ or ▲ and acknowledge with M .
	Activate key lock	Simultaneously press ▲ + ▼ for at least 5 s. The display must not change during this time. On activation, LOK and e. g. u3.1* appear in succession.
	Key lock active	Values or functions will be displayed but cannot be changed. LOCK will be displayed when attempting a change.
	Deactivate key lock	Simultaneously press ▲ + ▼ for at least 5 s. (siehe Kapitel 10 „User Level Dialog“, dialog item: CODE)
	Return to measuring mode	If no entry is made for 2 minutes, the switch automatically returns to the measuring mode without accepting the entries.
	Terminate programming	Press M for at least 5 s to change to the measuring mode.

* Software version no.

10 User Level Dialog

(xxxx = 125% v. f. s.)

Dialog item	Value	Description
MENU	-1... 9999	Primary display, e.g. the value selected in the DISP menu
DISP	----	Display value which should be permanently in the display: act actually measured value sp1 switching point SP1 SP2 switching point SP2 max maximum peak value min minimum peak value
ACT.	-1... 9999	Display of actually measured value in bar
UNIT (only V 7.X)		Fixing the unit (The unit is shown in the display appr. every 30 sec for appr. 5 sec) bar bar = bar psi psi x = psi x 10 psi psi = psi hPa hPa = Hekto-Pascal mbar mbar = millibar NOTE: no choice of the unit possible at UTS 7. Only °C possible!
SP.1	----	none switching output SP1 deactivated wind window technology stnd standard evaluation SP1 erro error output
ON-1	-1... xxxx	Switch-on point for SP1; NOTE: if the ON-value is set smaller than the OFF-value you receive a decreasing switch point evaluation.
OFF-1	-1... xxxx	Switch-off point for SP1
DLY1	0.0... 9.9 s	Switch-on / switch-off delay for SP2 in seconds
INV-1	----	Inversion of switching output SP1 hlfs high-level-fail-save (normally open function) llfs low-level-fail-save (normally closed function)
SP.2	----	none Switching output deactivated wind window technology stnd standard evaluation SP2 erro error output

Dialog item	Value	Description (continued)
ON-2	-1... xxxx	Switch-on point for SP2 NOTE: if the ON-value is set smaller than the OFF-value you receive a decreasing switch point evaluation.
OFF-2	-1... xxxx	Switch-off point for SP2
DLY2	0.0... 9.9 s	Switch-on / switch-off delay for SP2 in seconds
INV-2	----	Inversion of switching output SP2 hlfs high-level-fail-save (normally open function) llfs low-level-fail-save (normally closed function)
MAX -1	... xxxx	Display of the peak value "max"
CLR H	----	Delete the maximum value memory ---- no deletion clr delete value
CDLY	0.0... 9.9 s	Time setting to delete the maximum value memory after switching point SP1 is reached (manual deletion is still possible)
MIN	-1... xxxx	Display of the peak value "min"
CLR L	----	Delete the minimum value memory ---- no deletion clr delete value
OFFS	-9.9... +xx	Measured value offset in bar
CUT	0.0... +xx	Cut-off i.e. signal suppression at measuring range start in bar
DLDS	0.0... 9.9 s	Time delay for currently displayed value in seconds
ERRC	----	Error display: 0: -ok- no error 1: max exceeding pos. meas. range 2: min exceeding neg. meas. range 3: dig1 switching output 1 error 4: dig2 switching output 2 error 5: anao analog output error 6: sens sensor error 7: data data error (EEProm) 8: prog program error 9: cal calibration error